

LAN GÅMING SHËLF

THESE INSTRUCTIONS ARE FOR A 30" WIDE LAN GAMING SHELF TO FIT HALF OF A 5' TABLE.

DREAMHACK USES 5' TABLES AND QUAKECON USES 6' TABLES.

IF YOU WANT TO MAKE ONE FOR A 6' TABLE, JUST CHANGE 30 TO 36 IN ALL THE WOOD CUTS. BUT DON'T DO THAT. JUST MAKE THE 30" VERSION SO IT WORKS FOR BOTH TABLE SIZES.

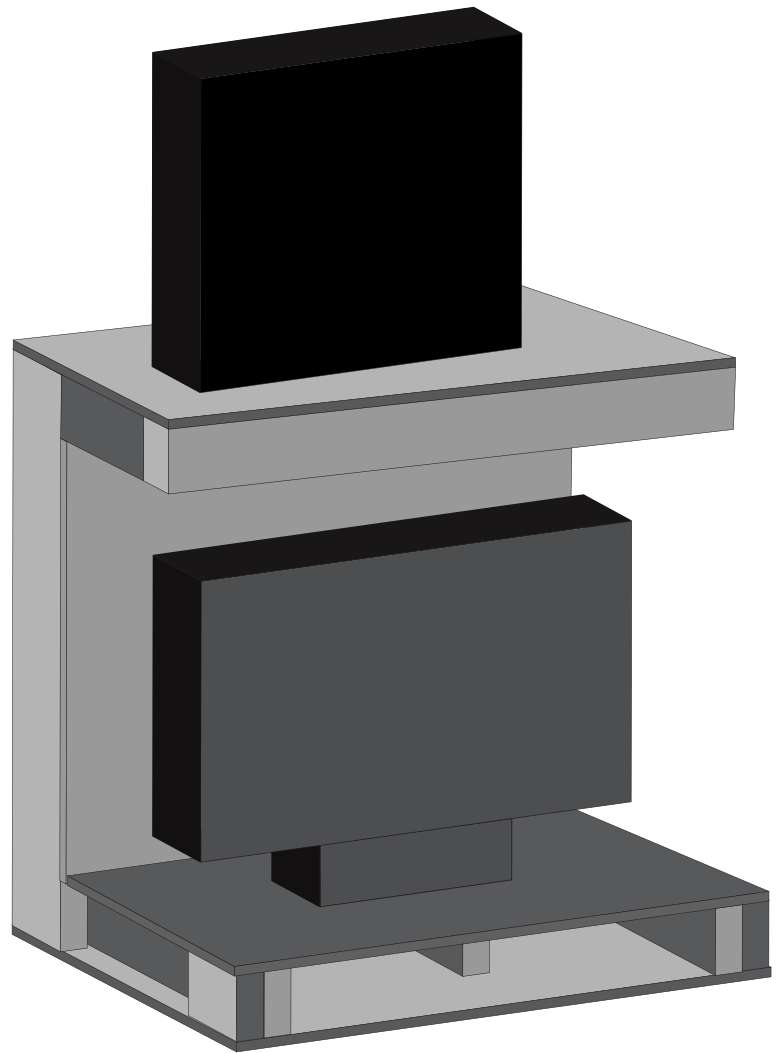

QNN

TOOLS REQUIRED

SCREWS, NAILS*, TAPE* OR JUST SOMETHING TO HOLD THE DAMN BOARDS TOGETHER*

SCREWDRIVER OR SOMETHING

MITER SAW OR SOME SORT OF CUTTING UTINSIL FOR THE 2X4s. PLEASE HAVE THE STORE CUT THE PLYWOOD. YOU **WILL DIE** IF YOU USE A TABLE SAW.

HALF A BRAIN** - WE CAN'T SPELL IT ALL OUT FOR YOU

*USE SCREWS.
WHAT'S WRONG
WITH YOU?

**FULL BRAIN
PREFERRED.

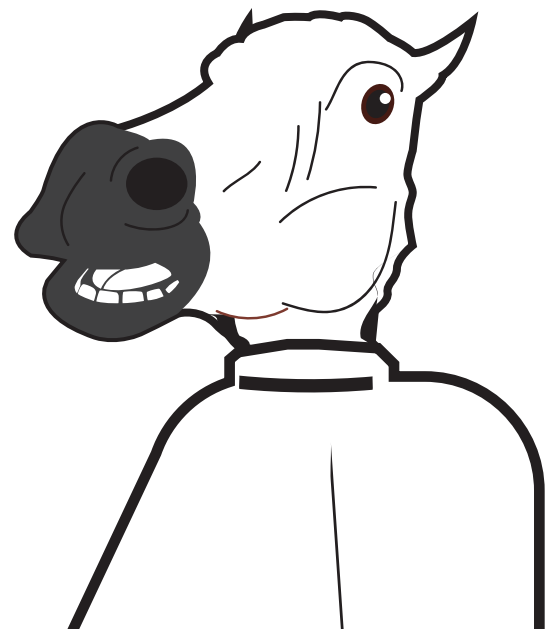

SHOPPING LIST

- 4'x8' 1/4" Plywood
- TWO 2"x4" boards - 10'
- CLAMPS

CUTS

15/32" Board

- 15"x30" - QTY 2
- 11"x30"
- 23"x30"
- 5.5"x30"

2"x4"

- 30" - QTY 4
- 15" - QTY 2
- 11.5" - QTY 1
- 10" - QTY 3
- 3.5" - QTY 4

NOTES

YOU CAN'T TELL FROM THE COVER, BUT THERE'S A SHELF ABOVE AND BELOW THE MONITOR FOR YOUR PURSE OR WHATEVER.

YOU CAN SET YOUR MONITOR ON THE PLATFORM OR MOUNT IT TO THE BACK WALL.

THE SIDES AND THE BACK HAVE PLYWOOD EXPOSED ON THE BOTTOM SO YOU CAN CLAMP IT TO THE TABLE. USE ONE CLAMP IN BACK AND ONE ON EITHER THE SIDE DEPENDING ON WHICH SIDE OF THE TABLE YOU'RE ON. **PLEASE DON'T SKIP THIS STEP.** THE LAST THING YOU WANT IS FOR YOUR STUFF TO TOPPLE OVER AND HIT ME.

PAINT OR STAIN THE DAMN THING. MAKE IT CLASSY.

PRE-DRILL YOUR HOLES SO YOU DON'T SPLIT YOUR WOOD. WE ALL KNOW HOW PAINFUL THAT IS...

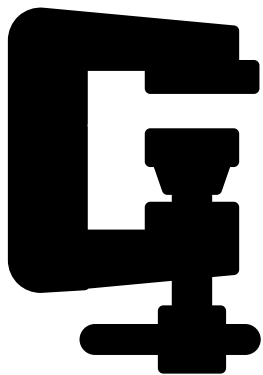

1

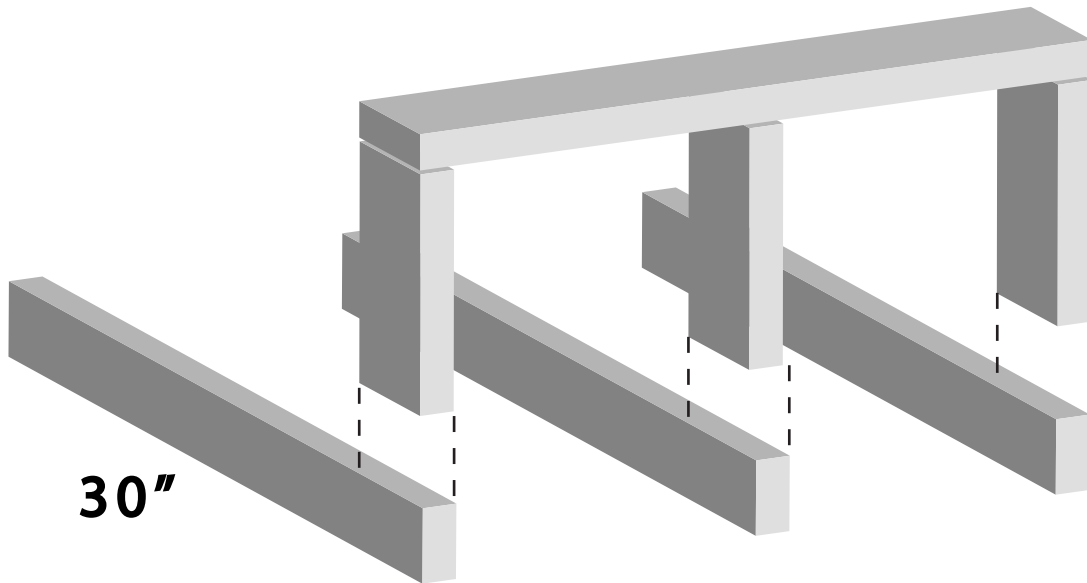
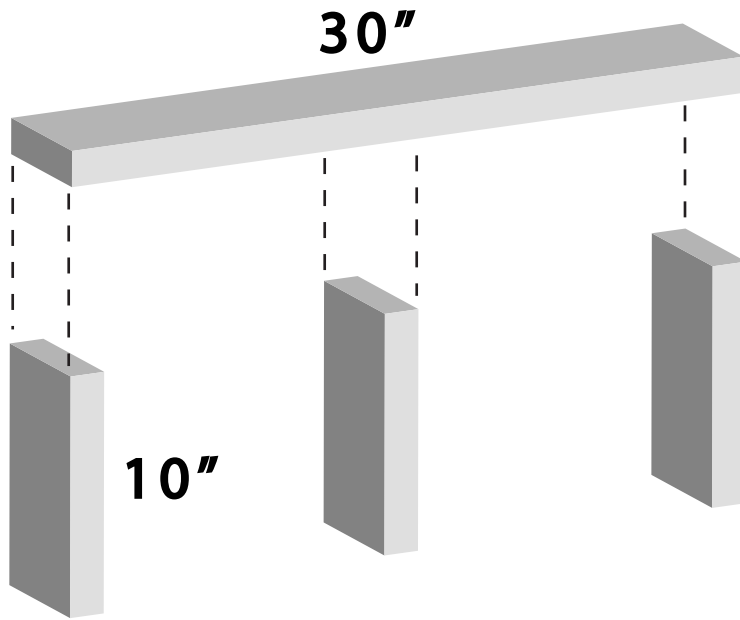

2

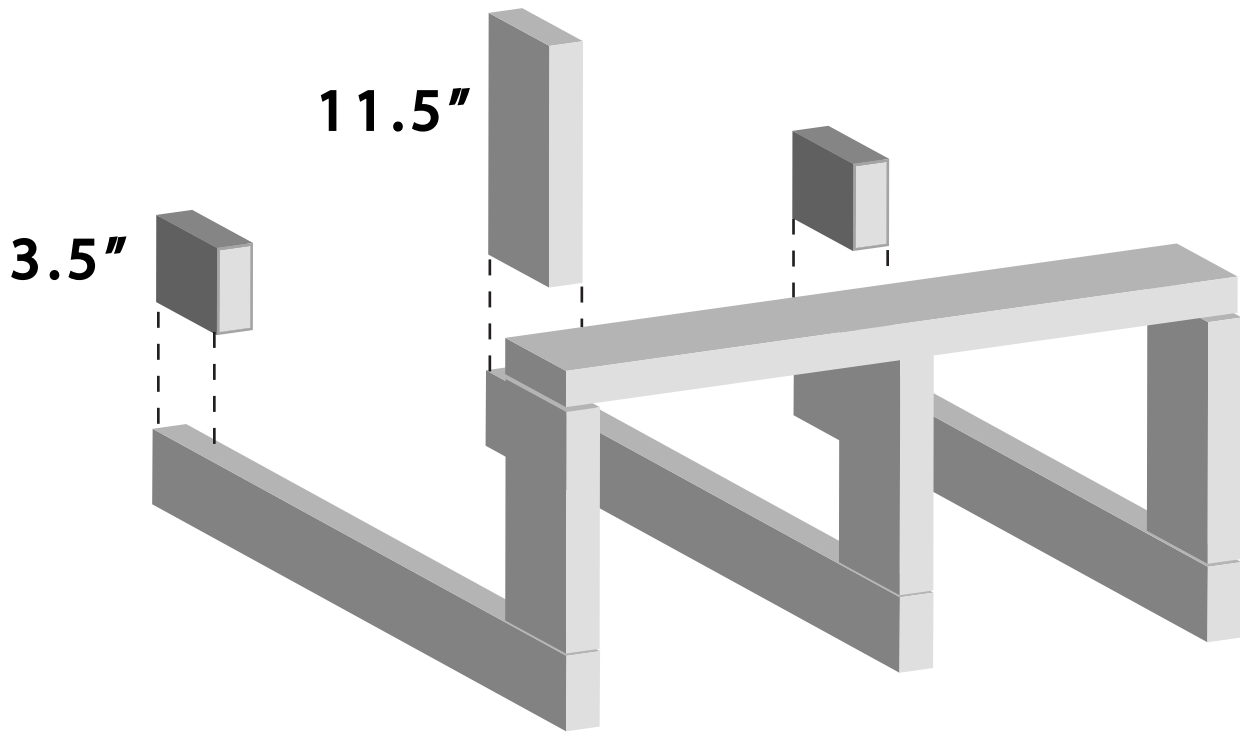

3 a

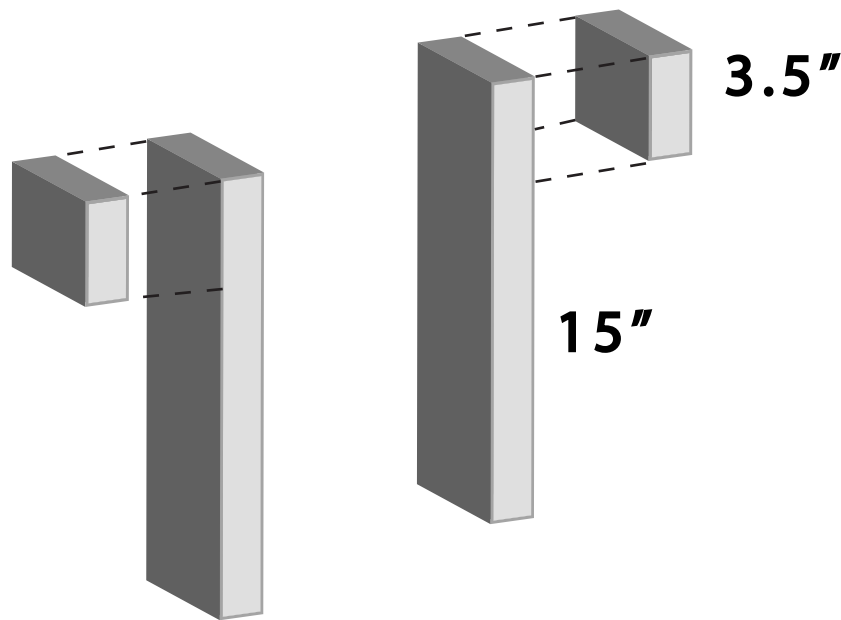

3 b

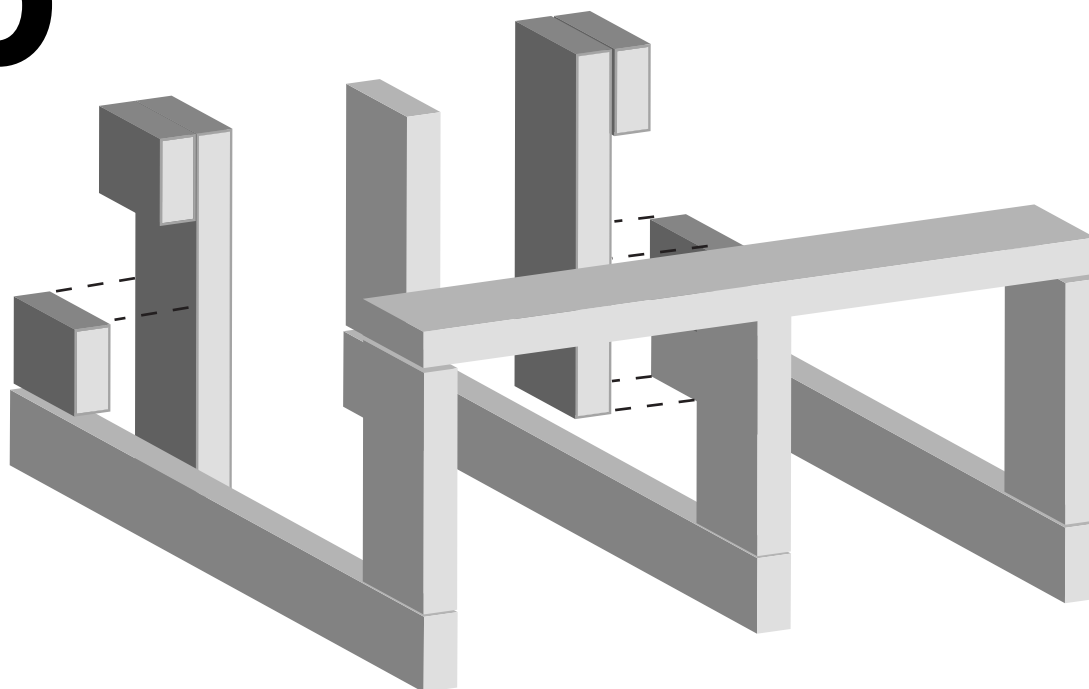

4

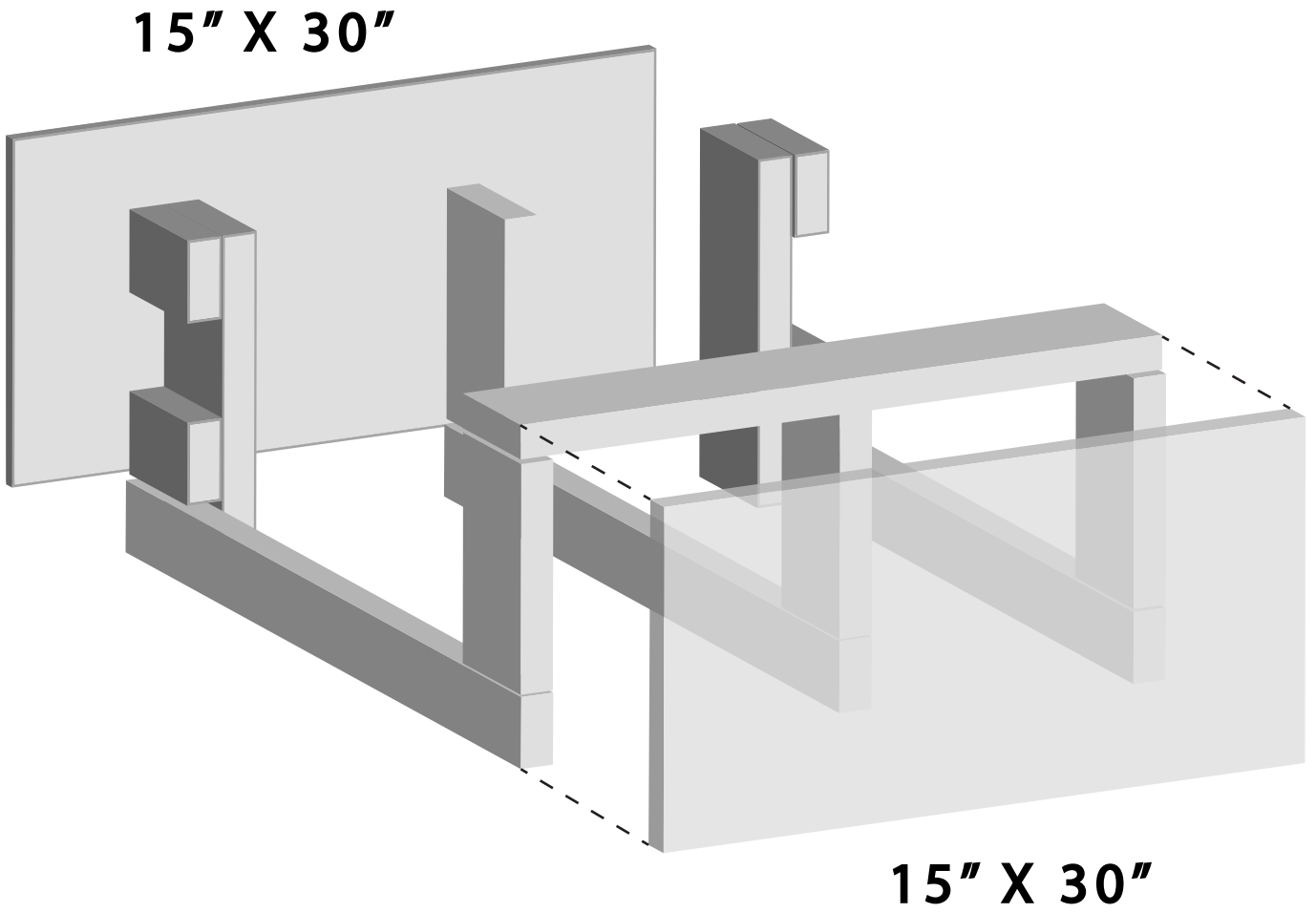

5

23" X 30"

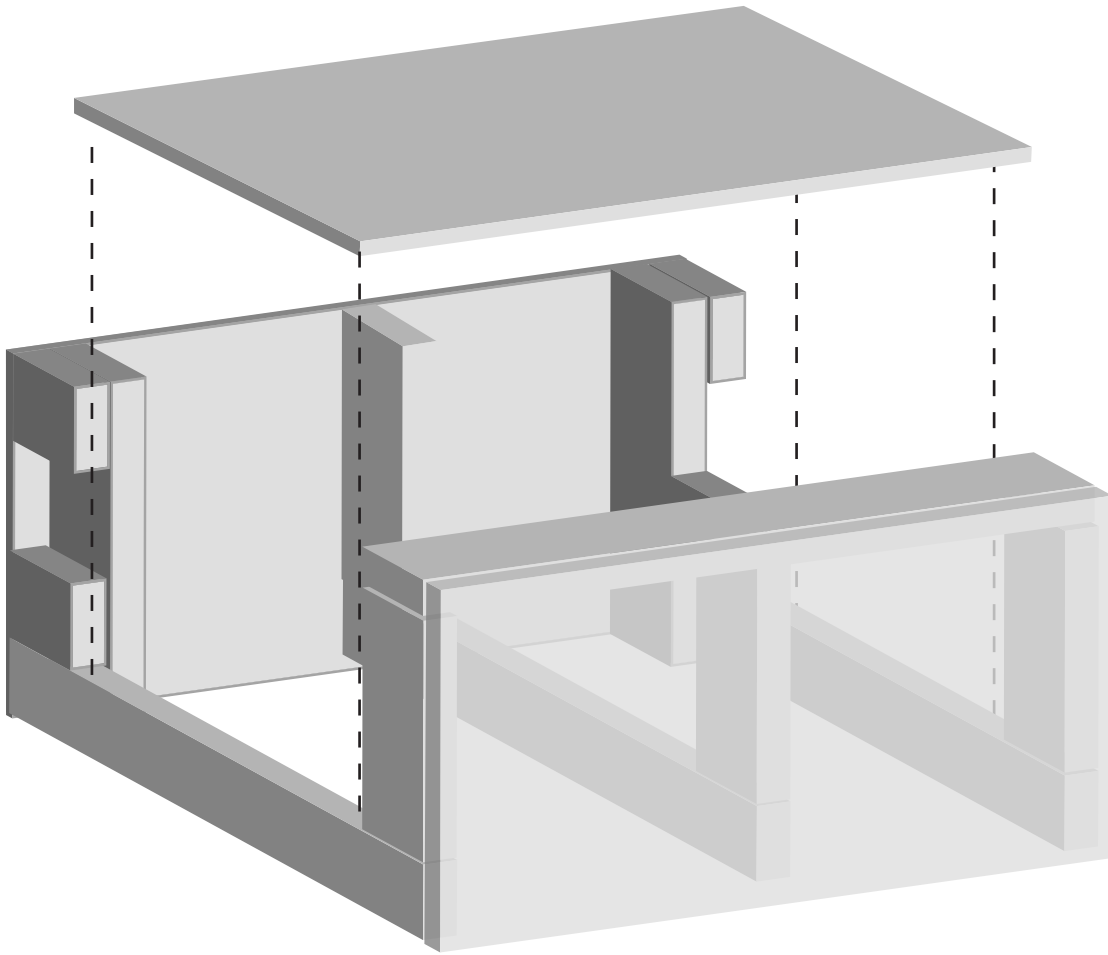

6

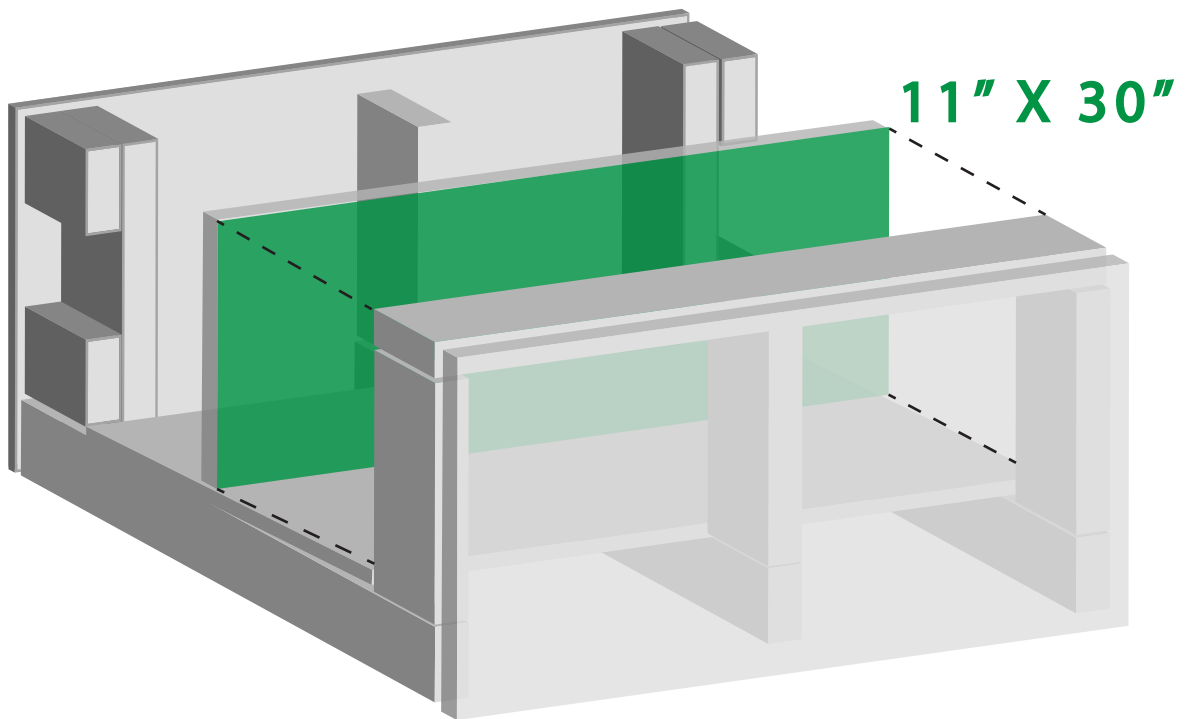

7

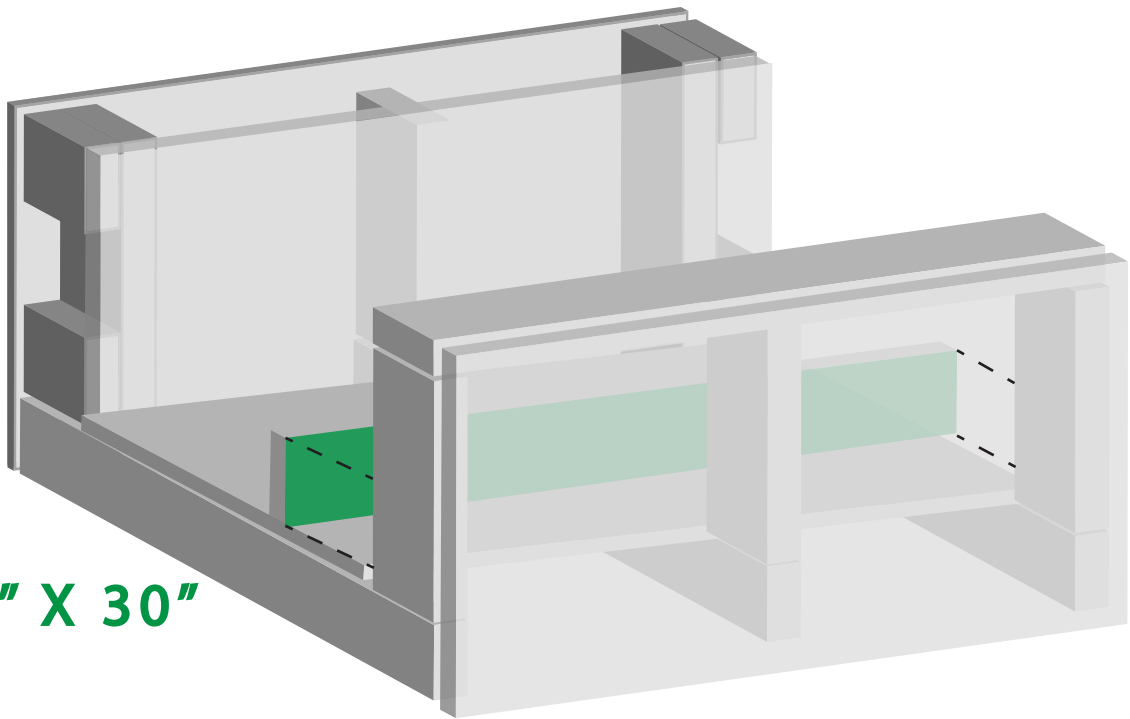

5.5" X 30"

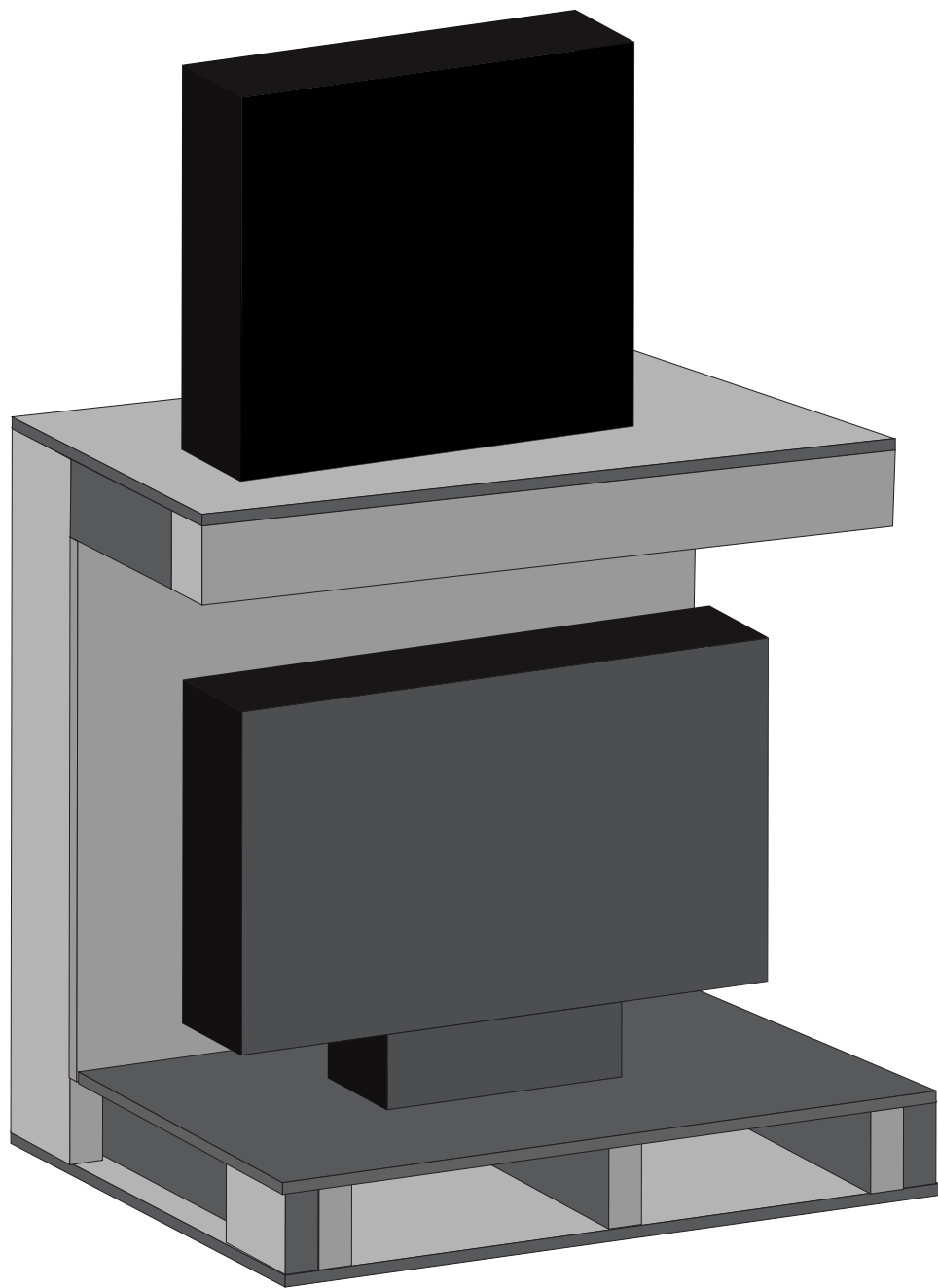

8

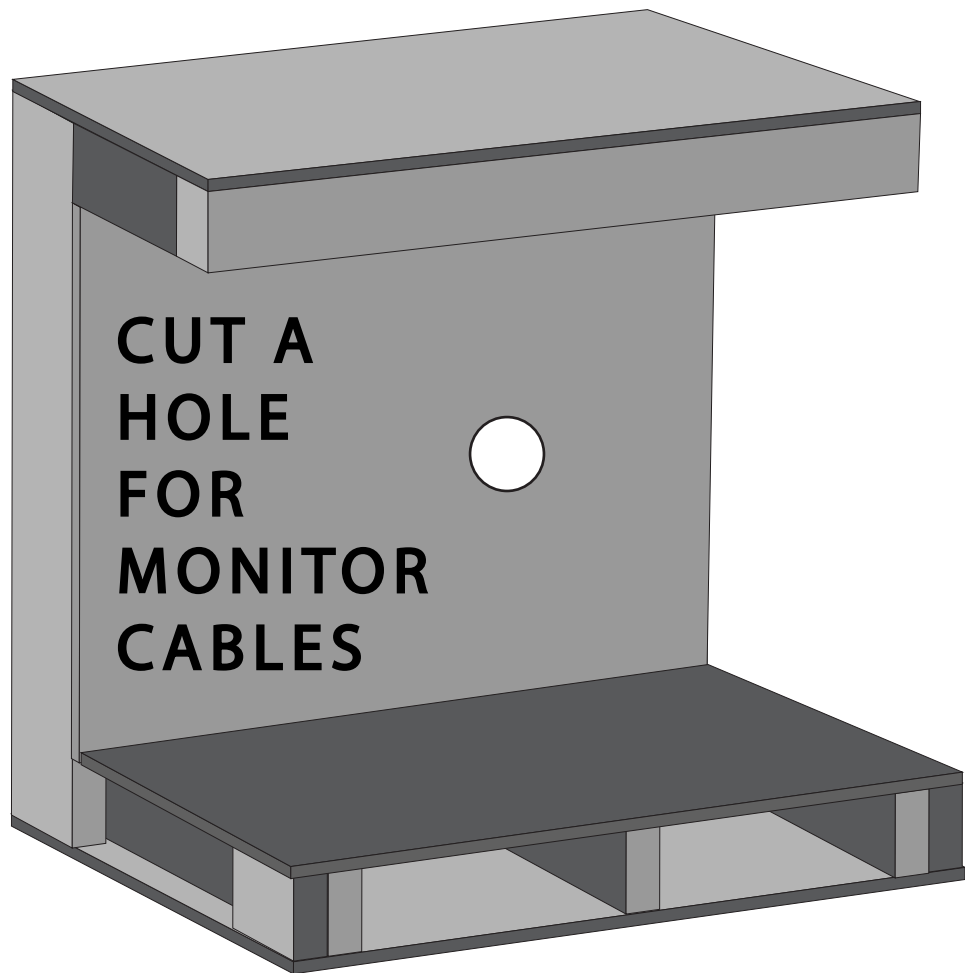

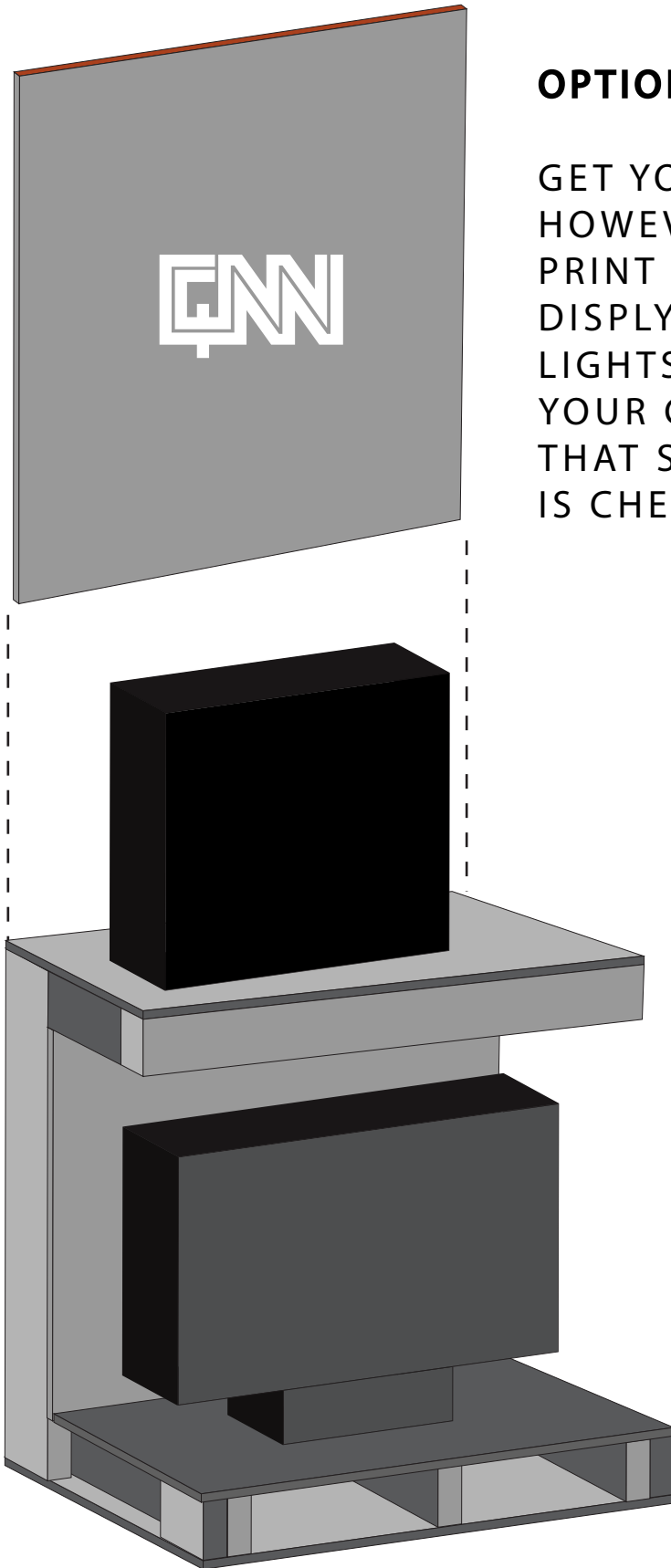

OPTIONAL:

GET YOURSELF A 30" WIDE BY HOWEVER TALL FOAMBOARD PRINT AND HAVE A COOL DISPLY ON TOP. PUT SOME LED LIGHTS ON THE BACKSIDE OF YOUR COMPUTER TO LIGHT THAT SUCKER UP. SIGNS.COM IS CHEAP.

LAN GÅMING SHËLF



GNN